

**RADIALL®**

SALES DRAWING

616 122

Sogie division

Edition : \_\_\_\_\_

Page \_\_\_\_\_

**TITRE :** SIZE 5 COAXIAL SOCKET CONTACT  
 FOR CABLE RG 316 RG 174 RG 188 RG 179

SERIE : DSX

PEN : \_\_\_\_\_

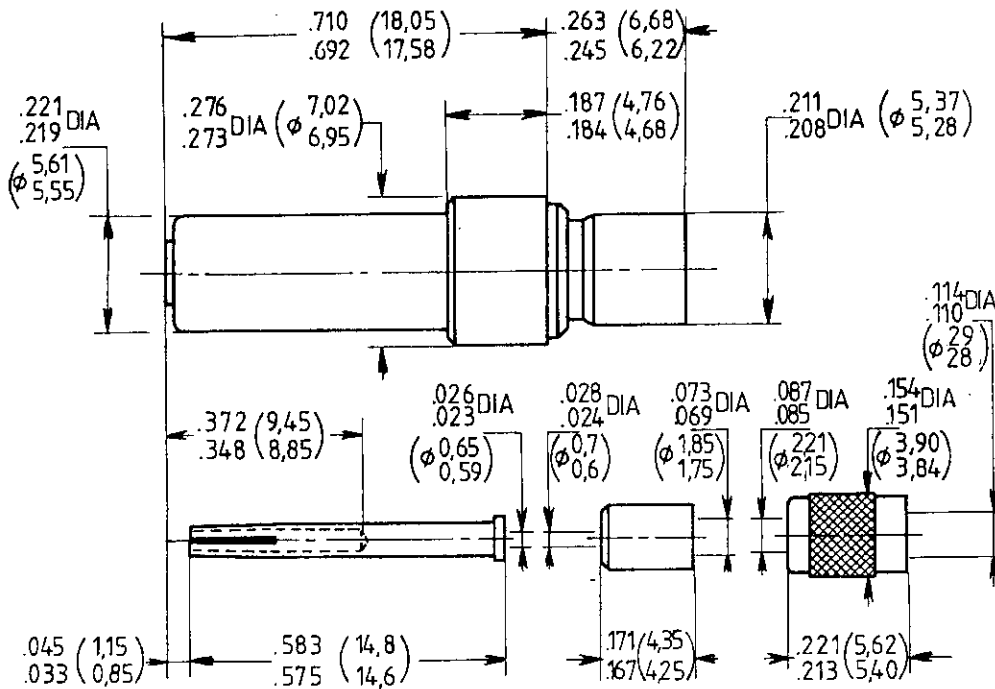

- 1°) Trim jacket to 10 mm (.394) dimension, then slide ferrule over braid, until it butts against the jacket. Comb out exposed braid.

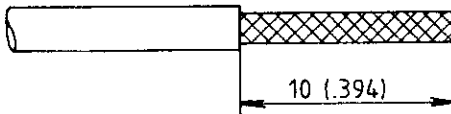

- 2°) Fold combed braid over ferrule. Trim dielectric; slide rear insulator on dielectric until it butts. Slide centre contact over conductor then crimp  
 Crimping tool M22520/2.01 (Radiall 282281) selector position 7 (6 for RG 179) positioner Radiall 282974.

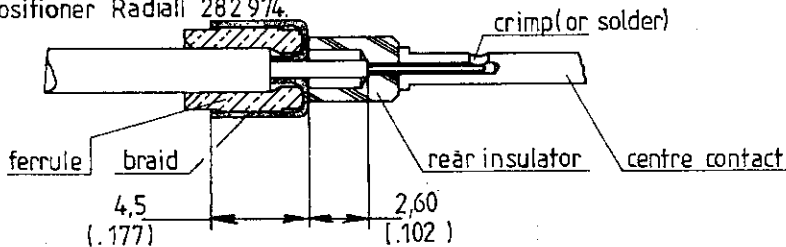

- 3°) Insert the part into body, ensuring they are pushed home, then crimp barrel  
 Crimping tool M22520/5.01 (Radiall 282293), die M22520/5.05 (Radiall 282246)  
 Hex.: B

IND	MODIFICATIONS	DATE	VISA
Création	Date 21_6_89		
Mise à jour	Date _____		

Ces renseignements vous sont donnés à titre indicatif. Dans le but constant d'améliorer nos produits, nous nous réservons le droit d'apporter toutes modifications jugées utiles.



101, Rue Ph. Hoffmann - Z.I. Ouest  
 93116 ROSNY/S/BOIS Cedex (France)  
 Tel. : (1) 48 54 80 40  
 Fax : (1) 48 54 63 63  
 Telex: Radia A 220673 F